

Restrained Spring Isolators Model FLS-1 and FLS-2

Description

Kinetics Model FLS vibration isolators consist of free-standing, large diameter, laterally stable steel springs assembled into welded steel housing assemblies fabricated to limit vertical movement of the isolated equipment if equipment loads are reduced, or if the equipment is subjected to large vertical external forces. The housings also provide a constant free and operating height to facilitate installation. Spring elements are complete with internal noise isolation pads and have an adjusting and leveling bolt as a part of the top load plate assembly. Springs are polyester powder coated, with a 1000-hour salt spray rating per ASTM B-117. Holes are provided in all isolators for bolting to the structure and to the supported equipment. The isolator can be welded to the structure as well. To assure stability, the springs have lateral spring stiffness greater than 1.0 times the rated vertical stiffness, and are designed to provide a minimum of 50% overload capacity. FLS Springs are available with deflections to 2" (51 mm) and with load capacities to 18,000 lbs. (8165 kg) as standard products. Custom isolators with higher deflection and greater load capabilities are available. Kinetics Model FLS spring isolators are recommended for the isolation of vibration producing equipment carrying a large fluid load which may be drained, such as boilers and chillers, and for the isolation of outdoor components such as cooling towers, air-cooled condensers, etc., where wind loads are minimal.

Application

Kinetics Model FLS vertically restrained spring isolation mounts are recommended as a noise and vibration isolator for mechanical equipment located near critically quiet areas, when the equipment to be isolated has significant changes of weight during maintenance operations, and for equipment subjected to moderate external forces or wind loads.

Operating static deflections are available up to 2" (51 mm) to compensate for long span flexible floor structures and maintain a high degree of noise and vibration isolation.

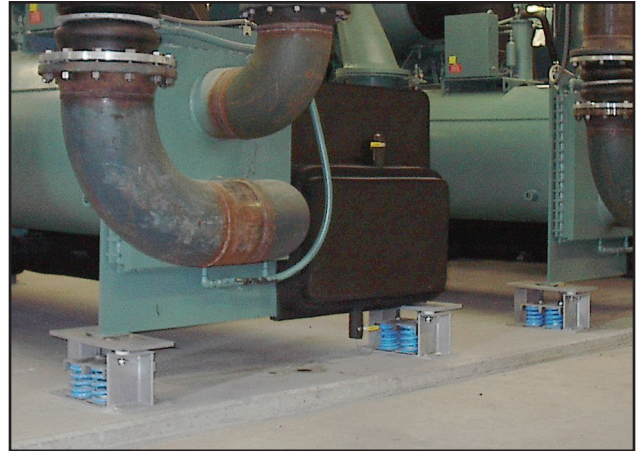

Specification

Vibration isolators for equipment which are subject to load variations and large external or torquing forces shall consist of large diameter, laterally stable steel springs assembled into welded steel housing assemblies designed to limit vertical movement of the supported equipment.

Housing assembly shall be of fabricated steel members and shall consist of a top load plate complete with adjusting and leveling bolts, vertical restraints, isolation washers and a bottom plate with internal non-skid noise isolation pads and holes provided for anchoring to supporting structure. Housing shall be hot dip galvanized for corrosion resistance. Housing should be designed to provide a constant free and operating height within 1/8" (0.06 mm).

Spring elements shall have a lateral stiffness greater than 1.0 times the rated vertical stiffness and shall be designed to provide a minimum of 50% overload capacity.

Springs shall be selected to provide static deflections shown on the Vibration Isolation Schedule or as indicated on the project documents. Springs shall be color coded or otherwise identified to indicate load capacity. Vibration isolators shall be Model FLS, as manufactured by Kinetics Noise Control, Inc.

Isolator Type	Spring Color	Rated Capacity		Rated Deflection		Spring O.D.		L		W		D		d		H	
		lbs.	kg	in.	mm	in.	mm	in.	mm	in.	mm	in.	mm	in.	mm	in.	mm
FLS-1-35	Blue	35	16	1.52	39	1.75	44	6.50	165	3.00	76	0.56	14	0.44	11	4.44	113
FLS-1-70	Green	70	32	1.36	35	1.75	44	6.50	165	3.00	76	0.56	14	0.44	11	4.44	113
FLS-1-120	Gray	120	54	1.18	30	1.75	44	6.50	165	3.00	76	0.56	14	0.44	11	4.44	113
FLS-1-220	Brown	220	100	1.07	27	1.75	44	6.50	165	3.00	76	0.56	14	0.44	11	4.44	113
FLS-1-370	Orange	370	168	0.96	24	1.75	44	6.50	165	3.00	76	0.56	14	0.44	11	4.44	113
FLS-1-500	Beige	500	227	1.00	25	1.75	44	6.50	165	3.00	76	0.56	14	0.44	11	4.44	113
FLS-1-600	Chrome	600	272	1.00	25	1.75	44	6.50	165	3.00	76	0.56	14	0.44	11	4.44	113
FLS-1-700	Beige/Wht	700	318	1.00	25	1.75	44	6.50	165	3.00	76	0.56	14	0.44	11	4.44	113
FLS-1-805	Chrm/Wht	805	365	1.01	26	1.75	44	6.50	165	3.00	76	0.56	14	0.44	11	4.44	113
FLS-1-50	Beige	50	23	1.00	25	3.00	76	8.75	222	4.00	102	0.69	17	0.56	14	6.25	159
FLS-1-100	Chrome	100	45	1.00	25	3.00	76	8.75	222	4.00	102	0.69	17	0.56	14	6.25	159
FLS-1-250	Blue	250	113	1.79	45	3.00	76	8.75	222	4.00	102	0.69	17	0.56	14	6.25	159
FLS-1-450	Green	450	204	1.54	39	3.00	76	8.75	222	4.00	102	0.69	17	0.56	14	6.25	159
FLS-1-625	Black	625	283	1.44	37	3.00	76	8.75	222	4.00	102	0.69	17	0.56	14	6.25	159
FLS-1-800	Gray	800	363	1.31	33	3.00	76	8.75	222	4.00	102	0.69	17	0.56	14	6.25	159
FLS-1-1000	Red	1000	454	1.15	29	3.00	76	8.75	222	4.00	102	0.69	17	0.56	14	6.25	159
FLS-1-1250	Brown	1250	567	1.09	28	3.00	76	8.75	222	4.00	102	0.69	17	0.56	14	6.25	159
FLS-1-1700	Orange	1700	771	0.95	24	3.00	76	8.75	222	4.00	102	0.69	17	0.56	14	6.25	159
FLS-1-2200	Org/Gray	2200	998	1.00	26	3.00	76	8.75	222	4.00	102	0.69	17	0.56	14	6.25	159
FLS-1-2465	Blue	2465	1118	1.00	25	3.00	76	8.75	222	4.00	102	0.69	17	0.56	14	6.25	159
FLS-1-2865	Blue/Gray	2865	1300	1.00	25	3.00	76	8.75	222	4.00	102	0.69	17	0.56	14	6.25	159
FLS-1-3500	Blue/Brn	3500	1588	1.00	25	3.00	76	8.75	222	4.00	102	0.69	17	0.56	14	6.25	159
FLS-1-2500	Brown	2500	1134	1.09	28	3.00	76	14.00	356	4.00	102	0.69	17	0.56	14	6.88	175
FLS-1-3400	Orange	3400	1542	0.95	24	3.00	76	14.00	356	4.00	102	0.69	17	0.56	14	6.88	175
FLS-1-4400	Org/Gray	4400	1996	1.00	26	3.00	76	14.00	356	4.00	102	0.69	17	0.56	14	6.88	175
FLS-1-4930	Blue	4930	2236	1.00	25	3.00	76	14.00	356	4.00	102	0.69	17	0.56	14	6.88	175
FLS-1-5730	Blue/Gray	5730	2599	1.00	25	3.00	76	14.00	356	4.00	102	0.69	17	0.56	14	6.88	175
FLS-1-7000	Blue/Brn	7000	3175	1.00	25	3.00	76	14.00	356	4.00	102	0.69	17	0.56	14	6.88	175
FLS-1-5000	Brown	5000	2270	1.09	28	3.00	76	16.50	419	8.00	203	0.81	21	0.69	17	7.50	191
FLS-1-6800	Orange	6800	3085	1.00	25	3.00	76	16.50	419	8.00	203	0.81	21	0.69	17	7.50	191
FLS-1-8800	Org/Gray	8800	3992	1.00	25	3.00	76	16.50	419	8.00	203	0.81	21	0.69	17	7.50	191
FLS-1-9860	Blue	9860	4472	1.00	25	3.00	76	16.50	419	8.00	203	0.81	21	0.69	17	7.50	191
FLS-1-11460	Blue/Gray	11460	5198	1.00	25	3.00	76	16.50	419	8.00	203	0.81	21	0.69	17	7.50	191
FLS-1-14000	Blue/Brn	14000	6350	1.00	25	3.00	76	16.50	419	8.00	203	0.81	21	0.69	17	7.50	191

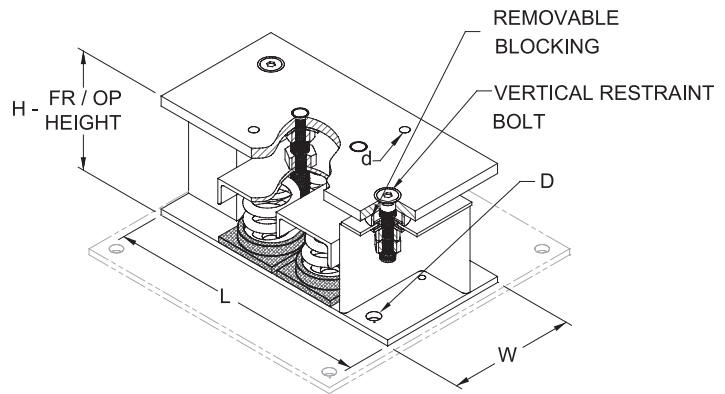
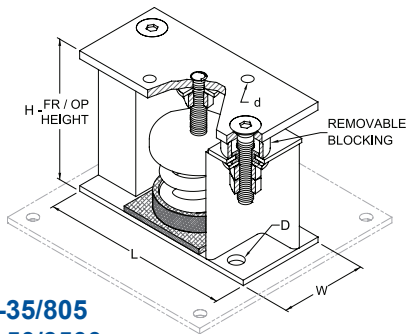

FLS-1-5000/15000

- FLS-1-35/805**
- FLS-1-50/3500**
- FLS-2-100/1975**
- FLS-2-2000/4500**

Isolator Type	Spring Color	Rated Capacity		Rated Deflection		Spring O.D.		L		W		D		d		H	
		lbs.	kg	in.	mm	in.	mm	in.	mm	in.	mm	in.	mm	in.	mm	in.	mm
FLS-2-100	Gray	100	45	2.00	51	3.50	89	9.00	229	5.00	127	0.69	17	0.56	14	8.00	203
FLS-2-135	Beige	135	61	2.00	51	3.50	89	9.00	229	5.00	127	0.69	17	0.56	14	8.00	203
FLS-2-185	Brown	185	84	2.00	51	3.50	89	9.00	229	5.00	127	0.69	17	0.56	14	8.00	203
FLS-2-225	Grey/Brn	225	102	2.00	51	3.50	89	9.00	229	5.00	127	0.69	17	0.56	14	8.00	203
FLS-2-250	Blue	250	113	2.00	51	3.50	89	9.00	229	5.00	127	0.69	17	0.56	14	8.00	203
FLS-2-375	Blue/Brn	375	170	2.00	51	3.50	89	9.00	229	5.00	127	0.69	17	0.56	14	8.00	203
FLS-2-500	Green	500	227	2.00	51	3.50	89	9.00	229	5.00	127	0.69	17	0.56	14	8.00	203
FLS-2-625	Grn/Brn	625	283	2.00	51	3.50	89	9.00	229	5.00	127	0.69	17	0.56	14	8.00	203
FLS-2-750	Black	750	340	2.00	51	3.50	89	9.00	229	5.00	127	0.69	17	0.56	14	8.00	203
FLS-2-875	Black/Brn	875	397	2.00	51	3.50	89	9.00	229	5.00	127	0.69	17	0.56	14	8.00	203
FLS-2-995	Orange	995	451	2.00	51	3.50	89	9.00	229	5.00	127	0.69	17	0.56	14	8.00	203
FLS-2-1120	Org/Brn	1120	508	2.00	51	3.50	89	9.00	229	5.00	127	0.69	17	0.56	14	8.00	203
FLS-2-1400	Org/Grn	1400	635	2.01	51	3.50	89	9.00	229	5.00	127	0.69	17	0.56	14	8.00	203
FLS-2-1600	Red	1600	726	2.00	51	3.50	89	9.00	229	5.00	127	0.69	17	0.56	14	8.00	203
FLS-2-1975	Red/Grn	1975	896	1.98	50	3.50	89	9.00	229	5.00	127	0.69	17	0.56	14	8.00	203
FLS-2-2000	Orange	2000	905	2.00	51	5.00	127	10.75	273	5.00	127	0.69	17	0.56	14	10.00	254
FLS-2-2500	Blue	2500	1135	2.00	51	5.00	127	10.75	273	5.00	127	0.69	17	0.56	14	10.00	254
FLS-2-2750	Blue/Blue	2750	1245	2.00	51	5.00	127	10.75	273	5.00	127	0.69	17	0.56	14	10.00	254
FLS-2-3025	Blue/Grn	3025	1375	2.00	51	5.00	127	10.75	273	5.00	127	0.69	17	0.56	14	10.00	254
FLS-2-3250	Blue/Blk	3250	1475	2.00	51	5.00	127	10.75	273	5.00	127	0.69	17	0.56	14	10.00	254
FLS-2-3500	Blu/Org	3500	1588	2.02	51	5.00	127	10.75	273	5.00	127	0.69	17	0.56	14	10.00	254
FLS-2-3900	Blu/Org/Grn	3900	1769	2.03	52	5.00	127	10.75	273	5.00	127	0.69	17	0.56	14	10.00	254
FLS-2-4100	Blue/Red	4100	1845	2.03	52	5.00	127	10.75	273	5.00	127	0.69	17	0.56	14	10.00	254
FLS-2-4500	Blu/Red/Grn	4500	2025	2.03	52	5.00	127	10.75	273	5.00	127	0.69	17	0.56	14	10.00	254
FLS-2-4000	Orange	4000	1815	2.00	51	5.00	127	17.50	445	6.00	152	0.69	17	0.56	14	10.00	254
FLS-2-5000	Blue	5000	2270	2.00	51	5.00	127	17.50	445	6.00	152	0.69	17	0.56	14	10.00	254
FLS-2-5500	Blue/Blue	5500	2495	2.00	51	5.00	127	17.50	445	6.00	152	0.69	17	0.56	14	10.00	254
FLS-2-6050	Blue/Grn	6050	2745	2.00	51	5.00	127	17.50	445	6.00	152	0.69	17	0.56	14	10.00	254
FLS-2-6500	Blue/Blk	6500	2950	2.00	51	5.00	127	17.50	445	6.00	152	0.69	17	0.56	14	10.00	254
FLS-2-7000	Blu/Org	7000	3175	2.02	51	5.00	127	17.50	445	6.00	152	0.69	17	0.56	14	10.00	254
FLS-2-7800	Blu/Org/Grn	7800	3538	2.03	52	5.00	127	17.50	445	6.00	152	0.69	17	0.56	14	10.00	254
FLS-2-8200	Blue/Red	8200	3690	2.00	51	5.00	127	17.50	445	6.00	152	0.69	17	0.56	14	10.00	254
FLS-2-9000	Blue/Red/Grn	9000	4050	2.00	51	5.00	127	17.50	445	6.00	152	0.69	17	0.56	14	10.00	254
FLS-2-8000	Orange	8000	3625	2.00	51	5.00	127	21.50	546	11.00	279	1.06	27	0.69	17	11.00	279
FLS-2-10000	Blue	10000	4535	2.00	51	5.00	127	21.50	546	11.00	279	1.06	27	0.69	17	11.00	279
FLS-2-11000	Blue/Blue	11000	4990	2.00	51	5.00	127	21.50	546	11.00	279	1.06	27	0.69	17	11.00	279
FLS-2-12100	Blue/Grn	12100	5490	2.00	51	5.00	127	21.50	546	11.00	279	1.06	27	0.69	17	11.00	279
FLS-2-13000	Blue/Blk	13000	5895	2.00	51	5.00	127	21.50	546	11.00	279	1.06	27	0.69	17	11.00	279
FLS-2-14000	Blue/Org	14000	6350	2.00	51	5.00	127	21.50	546	11.00	279	1.06	27	0.69	17	11.00	279
FLS-2-15600	Blu/Org/Grn	15600	7076	2.00	51	5.00	127	21.50	546	11.00	279	1.06	27	0.69	17	11.00	279
FLS-2-16400	Blue/Red	16400	7380	2.00	51	5.00	127	21.50	546	11.00	279	1.06	27	0.69	17	11.00	279
FLS-2-18000	Blu/Red/Grn	18000	8100	2.00	51	5.00	127	21.50	546	11.00	279	1.06	27	0.69	17	11.00	279

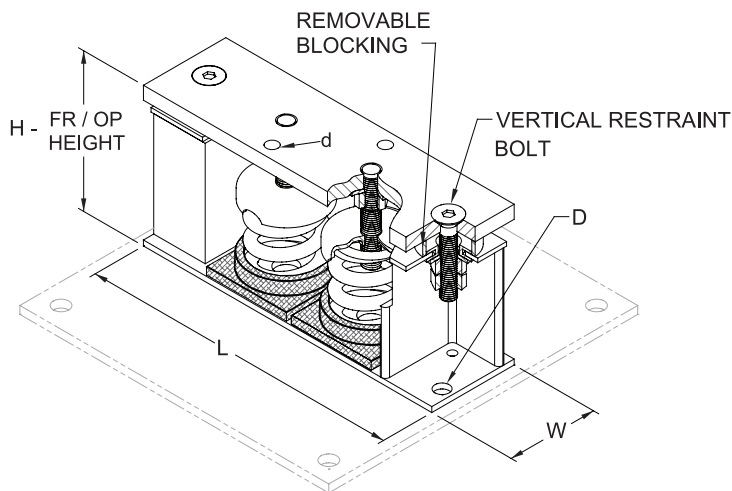

FLS-1-2500/7000
FLS-2-4000/9000

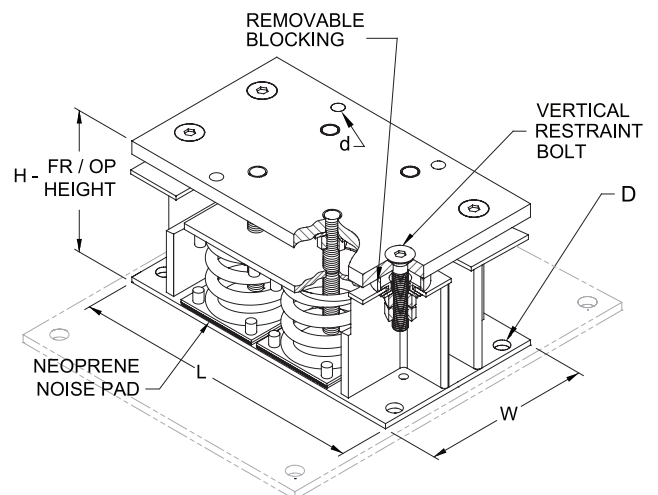

FLS-2-8000/18000



United States

6300 Irelan Place
P.O. Box 655
Dublin, Ohio 43017
Phone: 614-889-0480
Fax: 614-889-0540

Canada

3570 Nashua Drive
Mississauga, Ontario
L4V 1L2
Phone: 905-670-4922
Fax: 905-670-1698

www.kineticsnoise.com
sales@kineticsnoise.com

Kinetics Noise Control, Inc. is continually upgrading the quality of our products. We reserve the right to make changes to this and all products without notice.

Restrained Spring Isolators Model FLS-4

Description

Kinetics Model FLS Vibration Isolators consist of free-standing large diameter laterally stabile steel springs assembled into welded steel housing assemblies fabricated to limit vertical movement of the isolated equipment if equipment loads are reduced, or if the equipment is subjected to large external forces. The housings also provide a constant free and operating height to facilitate installation. Spring elements are complete with internal noise isolation pads and have an adjusting and leveling bolt as a part of the top load plate assembly. Springs are polyester powder coated, with a 1000 hour salt spray rating per ASTM B-117. Holes are provided in all isolators for bolting to the structure and to the supported equipment. The isolator can be welded to the structure as well. To assure stability, the springs have a lateral spring stiffness greater than 1.2 times the rated vertical stiffness, and are designed to provide a minimum of 50% overload capacity. FLS springs are available with deflections to 4 in. (102 mm) and with load capacities to 23,200 lbs. (10,524 kg) as standard products. Custom isolators with higher deflections and greater load capabilities are also available.

Application

Kinetics Model FLS vertically restrained spring isolation mounts are recommended as a noise and vibration isolator for mechanical equipment located near critically quiet areas, when the equipment to be isolated has significant changes of weight during maintenance operations, and for equipment subjected to external forces or high wind loads. Model FLS mounts are typically used to reduce the transmission of noise and vibration into supporting structures from equipment carrying a large fluid load that may be drained, such as boilers, cooling tower and chillers, and cooling towers which also require hold-down for wind loads.

Operating static deflections are available up to 4 in. (102 mm) to compensate for long span flexible floor structures and maintain a high degree of noise and vibration isolation.



Specification

Vibration isolators for equipment which is subject to load variations and large external or torquing forces shall consist of large diameter laterally stabile steel springs assembled into welded steel housing assemblies designed to limit vertical movement of the supported equipment.

Housing assemblies shall be fabricated steel members and shall consist of a top load plate complete with adjusting and leveling bolts, vertical restraints, isolation washers and a bottom plate with internal non-skid noise isolation pads. Housing shall be electrozinc plated or hot dip galvanized for corrosion resistance. Housing should be designed to provide a constant free and operating height within 1/8 in. (0.06 mm). Spring elements shall have a lateral stiffness greater than 1.2 times the rated vertical stiffness and shall be designed to provide a minimum of 50% overload capacity. Non-welded spring elements shall be polyester powder coated, and shall have a 1000 hr rating when tested in accordance with ASTM B-117.

Springs shall be selected to provide static deflections shown on the Vibration Isolation Schedule or as indicated on the project documents. Springs shall be color coded or otherwise identified to indicate load capacity. Vibration isolators shall be Model FLS, as manufactured by Kinetics Noise Control, Inc.

Isolator Type	Spring Color	Rated Capacity		Rated Deflection		Spring O.D.		L		W		D		d		H	
		lbs.	kg	in.	mm	in.	mm	in.	mm	in.	mm	in.	mm	in.	mm	in.	mm
FLS-4-100	Gray	100	45	4.00	102	5.63	143	10.75	273	6.00	152	0.69	17	0.56	14	14.00	330
FLS-4-250	Blue	250	113	4.00	102	5.63	143	10.75	273	6.00	152	0.69	17	0.56	14	14.00	330
FLS-4-500	Green	500	227	4.00	102	5.63	143	10.75	273	6.00	152	0.69	17	0.56	14	14.00	330
FLS-4-750	Black	750	340	4.00	102	5.63	143	10.75	273	6.00	152	0.69	17	0.56	14	14.00	330
FLS-4-1000	Red	1000	454	4.00	102	5.63	143	10.75	273	6.00	152	0.69	17	0.56	14	14.00	330
FLS-4-1250	Brown	1250	567	4.00	102	5.63	143	10.75	273	6.00	152	0.69	17	0.56	14	14.00	330
FLS-4-1600	Orange	1600	726	4.00	102	5.63	143	10.75	273	6.00	152	0.69	17	0.56	14	14.00	330
FLS-4-2250	Beige	2250	1021	4.00	102	8.00	203	15.50	394	8.00	203	0.69	17	0.69	17	17.25	378
FLS-4-2500	Beige/Blue	2500	1134	4.00	102	8.00	203	15.50	394	8.00	203	0.69	17	0.69	17	17.25	378
FLS-4-2750	Beige/Grn	2750	1247	4.00	102	8.00	203	15.50	394	8.00	203	0.69	17	0.69	17	17.25	378
FLS-4-3000	Beige/Blk	3000	1361	4.00	102	8.00	203	15.50	394	8.00	203	0.69	17	0.69	17	17.25	378
FLS-4-3250	Beige/Red	3250	1474	4.00	102	8.00	203	15.50	394	8.00	203	0.69	17	0.69	17	17.25	378
FLS-4-3500	Beige/Brn	3500	1588	4.00	102	8.00	203	15.50	394	8.00	203	0.69	17	0.69	17	17.25	378
FLS-4-3850	Beige/Org	3850	1746	4.00	102	8.00	203	15.50	394	8.00	203	0.69	17	0.69	17	17.25	378
FLS-4-4200	Chrome	4200	1905	4.00	102	8.00	203	15.50	394	8.00	203	0.69	17	0.69	17	17.25	378
FLS-4-4450	Chr/Blue	4450	2018	4.00	102	8.00	203	15.50	394	8.00	203	0.69	17	0.69	17	17.25	378
FLS-4-4700	Chr/Grn	4700	2132	4.00	102	8.00	203	15.50	394	8.00	203	0.69	17	0.69	17	17.25	378
FLS-4-4950	Chr/Blk	4950	2245	4.00	102	8.00	203	15.50	394	8.00	203	0.69	17	0.69	17	17.25	378
FLS-4-5200	Chr/Red	5200	2359	4.00	102	8.00	203	15.50	394	8.00	203	0.69	17	0.69	17	17.25	378
FLS-4-5450	Chr/Brn	5450	2472	4.00	102	8.00	203	15.50	394	8.00	203	0.69	17	0.69	17	17.25	378
FLS-4-5800	Chr/Org	5800	2631	4.00	102	8.00	203	15.50	394	8.00	203	0.69	17	0.69	17	17.25	378
FLS-4-5500	Beige/Grn	5500	2495	4.00	102	8.00	203	25.50	648	8.00	203	0.81	21	0.69	17	17.25	378
FLS-4-6000	Beige/Blk	6000	2722	4.00	102	8.00	203	25.50	648	8.00	203	0.81	21	0.69	17	17.25	378
FLS-4-6500	Beige/Red	6500	2948	4.00	102	8.00	203	25.50	648	8.00	203	0.81	21	0.69	17	17.25	378
FLS-4-7000	Beige/Brn	7000	3175	4.00	102	8.00	203	25.50	648	8.00	203	0.81	21	0.69	17	17.25	378
FLS-4-7700	Beige/Org	7700	3493	4.00	102	8.00	203	25.50	648	8.00	203	0.81	21	0.69	17	17.25	378
FLS-4-8400	Chrome	8400	3810	4.00	102	8.00	203	25.50	648	8.00	203	0.81	21	0.69	17	17.25	378
FLS-4-8900	Chr/Blue	8900	4037	4.00	102	8.00	203	25.50	648	8.00	203	0.81	21	0.69	17	17.25	378
FLS-4-9400	Chr/Green	9400	4264	4.00	102	8.00	203	25.50	648	8.00	203	0.81	21	0.69	17	17.25	378
FLS-4-9900	Chr/Black	9900	4491	4.00	102	8.00	203	25.50	648	8.00	203	0.81	21	0.69	17	17.25	378
FLS-4-10400	Chr/Red	10400	4717	4.00	102	8.00	203	25.50	648	8.00	203	0.81	21	0.69	17	17.25	378
FLS-4-10900	Chr/Brown	10900	4944	4.00	102	8.00	203	25.50	648	8.00	203	0.81	21	0.69	17	17.25	378
FLS-4-11600	Chr/Org	11600	5262	4.00	102	8.00	203	25.50	648	8.00	203	0.81	21	0.69	17	17.25	378
FLS-4-11000	Beige/Grn	11000	4990	4.00	102	8.00	203	27.00	686	17.00	432	0.81	21	0.69	17	17.25	381
FLS-4-12000	Beige/Blk	12000	5443	4.00	102	8.00	203	27.00	686	17.00	432	0.81	21	0.69	17	17.25	381
FLS-4-13000	Beige/Red	13000	5897	4.00	102	8.00	203	27.00	686	17.00	432	0.81	21	0.69	17	17.25	381
FLS-4-14000	Beige/Brn	14000	6350	4.00	102	8.00	203	27.00	686	17.00	432	0.81	21	0.69	17	17.25	381
FLS-4-15400	Beige/Org	15400	6985	4.00	102	8.00	203	27.00	686	17.00	432	0.81	21	0.69	17	17.25	381
FLS-4-16800	Chrome	16800	7620	4.00	102	8.00	203	27.00	686	17.00	432	0.81	21	0.69	17	17.25	381
FLS-4-17800	Chr/Blu	17800	8074	4.00	102	8.00	203	27.00	686	17.00	432	0.81	21	0.69	17	17.25	381
FLS-4-18800	Chr/Grn	18800	8528	4.00	102	8.00	203	27.00	686	17.00	432	0.81	21	0.69	17	17.25	381
FLS-4-19800	Chr/Blk	19800	8981	4.00	102	8.00	203	27.00	686	17.00	432	0.81	21	0.69	17	17.25	381
FLS-4-20800	Chr/Red	20800	9435	4.00	102	8.00	203	27.00	686	17.00	432	0.81	21	0.69	17	17.25	381
FLS-4-21800	Chr/Brn	21800	9888	4.00	102	8.00	203	27.00	686	17.00	432	0.81	21	0.69	17	17.25	381
FLS-4-23200	Chr/Org	23200	10523	4.00	102	8.00	203	27.00	686	17.00	432	0.81	21	0.69	17	17.25	381

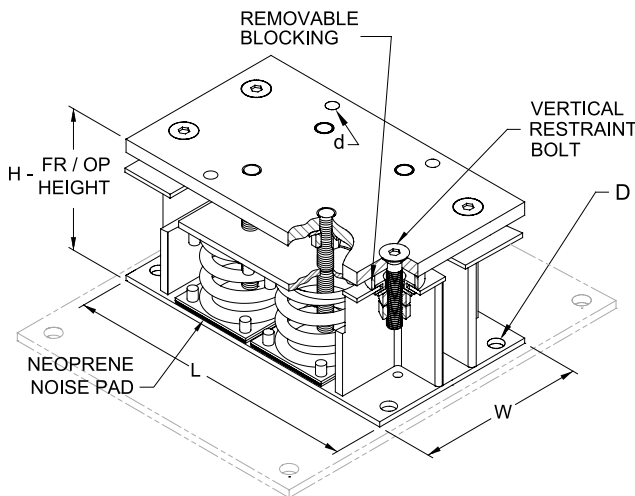

United States
6300 Irelan Place
P.O. Box 655
Dublin, Ohio 43017
Phone: 614-889-0480
Fax: 614-889-0540

Canada
3570 Nashua Drive
Mississauga, Ontario
L4V 1L2
Phone: 905-670-4922
Fax: 905-670-1698

www.kineticsnoise.com
sales@kineticsnoise.com

Kinetics Noise Control, Inc. is continually upgrading the quality of our products. We reserve the right to make changes to this and all products without notice.